

55 x 34 U

Lavabo in ceramica sottopiano senza troppo pieno e lato inferiore smaltato. Piletta esclusa.
Under-top ceramic washbasin without overflow and enamelled bottom. Drain not included.

Colorazioni/Colours



Codice/Code

Lavabo Washbasin		ALL03 [] A
Installazione Installation		Sottopiano Under-top
Troppo pieno Overflow		Senza troppo pieno Without overflow
Piletta Drain		Scarico libero Ø 7,2 cm Free flow Ø 7,2 cm
Smaltatura Enamelled		lato inferiore Bottom
Dimensioni Dimensions		55 x 34 x 4h cm
Peso Weight		9,90 kg
Capienza vasca Tank capacity		8,50 Lt
Pallet		100 x 120 x 120h 31 pz. 100 x 120 x 220h 40 pz. 80 x 120 x 180h 23 pz.

Fissaggi Hardware		Inclusi Included
Lavabo Washbasin		Senza foro No tap Hole

Raccomandata/Recommended
Codice/Code : PI2FCI 1A



Piletta Scarico libero in abs cromato con tappo in ceramica standard Ø 7,2 cm.
Chromed abs Free flow drain with standard ceramic plug Ø 7,2 cm.

Accessori/Accessories
Codice/Code: PI2FACRA



Piletta Scarico libero in abs cromato con tappo cromato Ø 7,2 cm.
Chromed abs Free flow drain with chromed plug Ø 7,2 cm.

Codice/Code: SI1TOCRA



Sifone tondo in ottone cromato per lavabo
Round siphon in chrome-plated brass for washbasin

CE EN 14688 - CL00

Lavabo
Washbasin

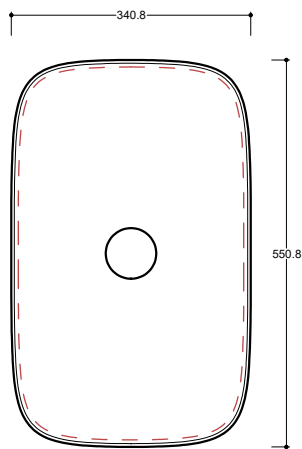
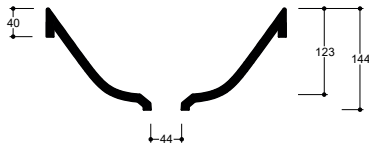

Sottopiano
Under-top

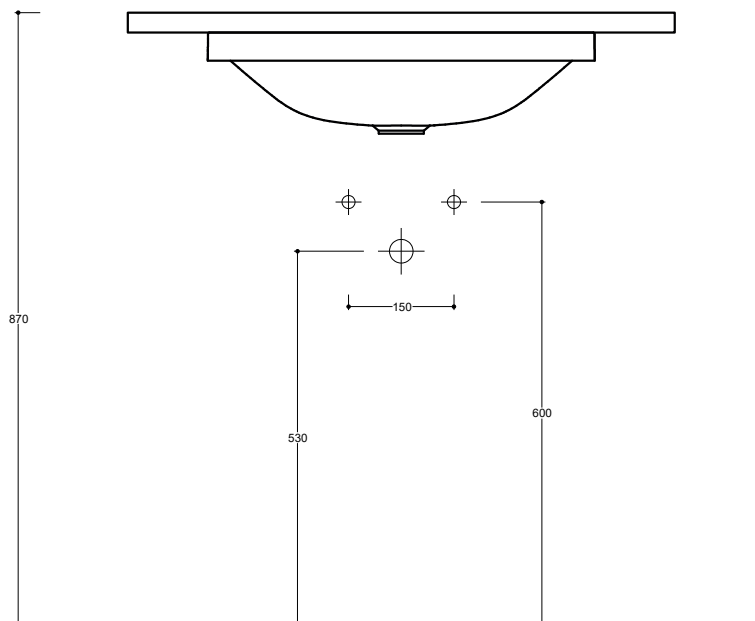

■ Dima di taglio

NB Le misure indicate possono subire una variazione dello 0,8 % circa, dovuta ad un'usura degli stampi o a piccole variazioni delle caratteristiche tecniche relative alle materie prime che compongono l'impasto.
NB Dimensions shown are subject to a variation of about 0,8 % , due to wear of molds or because of small changes in the technical specification of the raw materials of the dough.

ATTENZIONE le quote di installazione si riferiscono ad un impianto standard, sono generiche ed indicative. Si consiglia di adattare le quote in base alle esigenze del cliente.
ATTENTION the installation sheets refer to a standard system, they are generic and indicative. We recommend adapting the dimensions according to customer needs.

LUGLIO 2020